

# PUMP SHUTOFF MICROSWITCH KIT #100796

Please read complete instructions before replacing components.

## Parts Included

Part #	Qty	Description
60017	1	MICROSWITCH, SHORT ARM

## Assembly Instructions

1. Ensure that the correct microswitch is included in your replacement kit. The switch should be marked "V3L-1108-D8", or "V-5612D".
2. Turn main power switch on distiller off and unplug cord from wall plug. Disconnect float box connector cable from distiller head. Lift head off of holding tank.
3. Remove the float box cover by removing the 2 screws.
4. Remove the screws and kep nuts attaching the switch to the float box. One wire at a time, disconnect the wires attached to the old microswitch and connect to the new one. Note the location and routing of these wires. Ensure you are connecting to the normally open (NO) terminal and not the normally closed (NC).
5. Install the new switch, ensuring that the wires do not interfere with float motion.
6. Replace float box cover. Place distiller head on holding tank and connect float box cable to head.

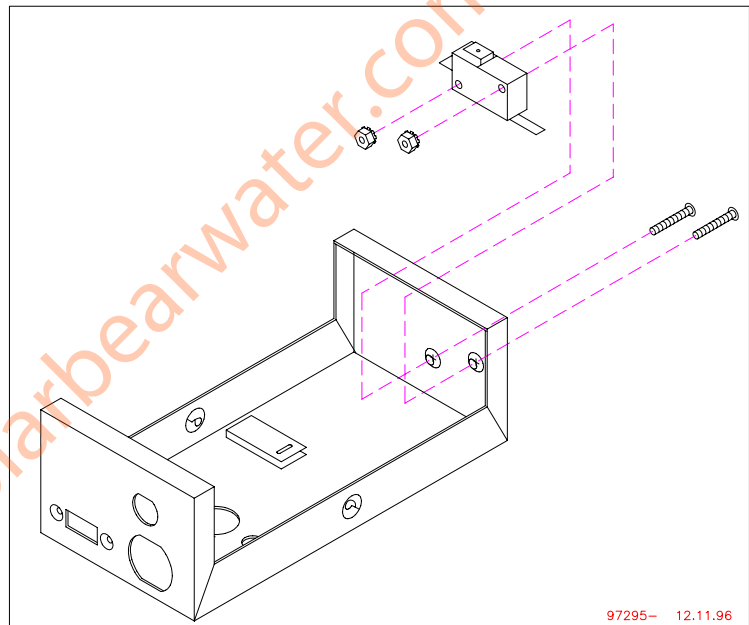

The distiller should now operate properly. If it does not, confirm that the wires are connected to the proper location by referring to your electrical schematic. If they appear correct, we suggest you take your distiller to an authorized service representative.